

TECHNICAL SPECIFICATIONS

Techno

3/4" Thermostatic valve without volume control

code | 221 616 xxx

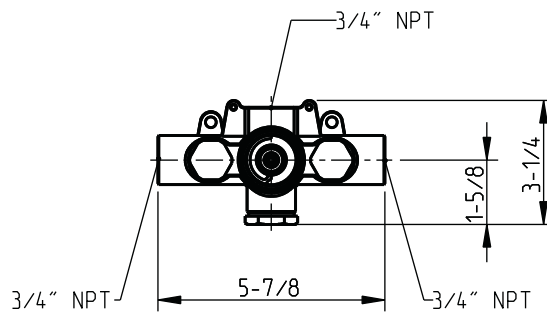
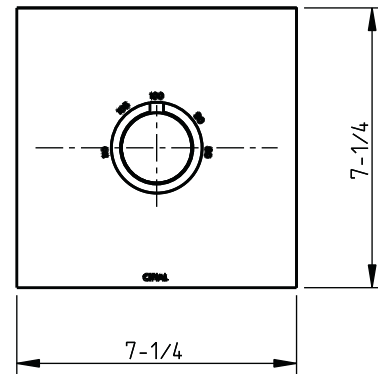
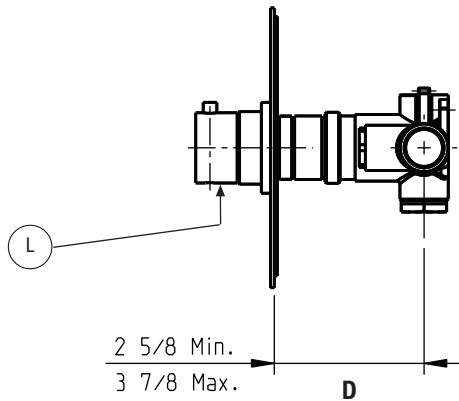

INSTALLER:
Please leave all leaflets with the building owner to file for future reference.

Rough: 289 717 999 (sold separately)

L Identification and certification label position.

5663586
983TH014W00

dimensions inches

PLUMBING

CIFIAL USA
USA P +1800 5284904 F +1800 5281969 info@cifialusa.com www.cifialusa.com

CIFIAL Torneiras, S.A.
Portugal T +351 256 780 700 F +351 256 780 710 cifial@cifial.pt www.cifial.pt

CIFIALDECOR, S.A.
Espanha T +34 916 110 261 F +34 916 103 694 cifialdecor@infonegocio.com

CIFIAL UK, Ltd.
UK P +44 1933 402 008 F +44 1933 402 063 sales@cifial.co.uk www.cifial.co.uk



Part N°	Assignment	Amount
1	Rough valve	1
2	End Cap	2
3	Non-return valve	2
4	Filter	2
5	Thermostatic cartridge	1
6	Plug	1
7	Temperature limit ring	1
8	Thermo cartridge extension	1
9	Set screw	1
10	Spline extension	1
11	Spline extension screw	1
12	Face plate	1
13	Rosette	1
14	Finished trim ring	1
15	Temperature control handle	1
16	Set screw	1
17	Set screw cover	1

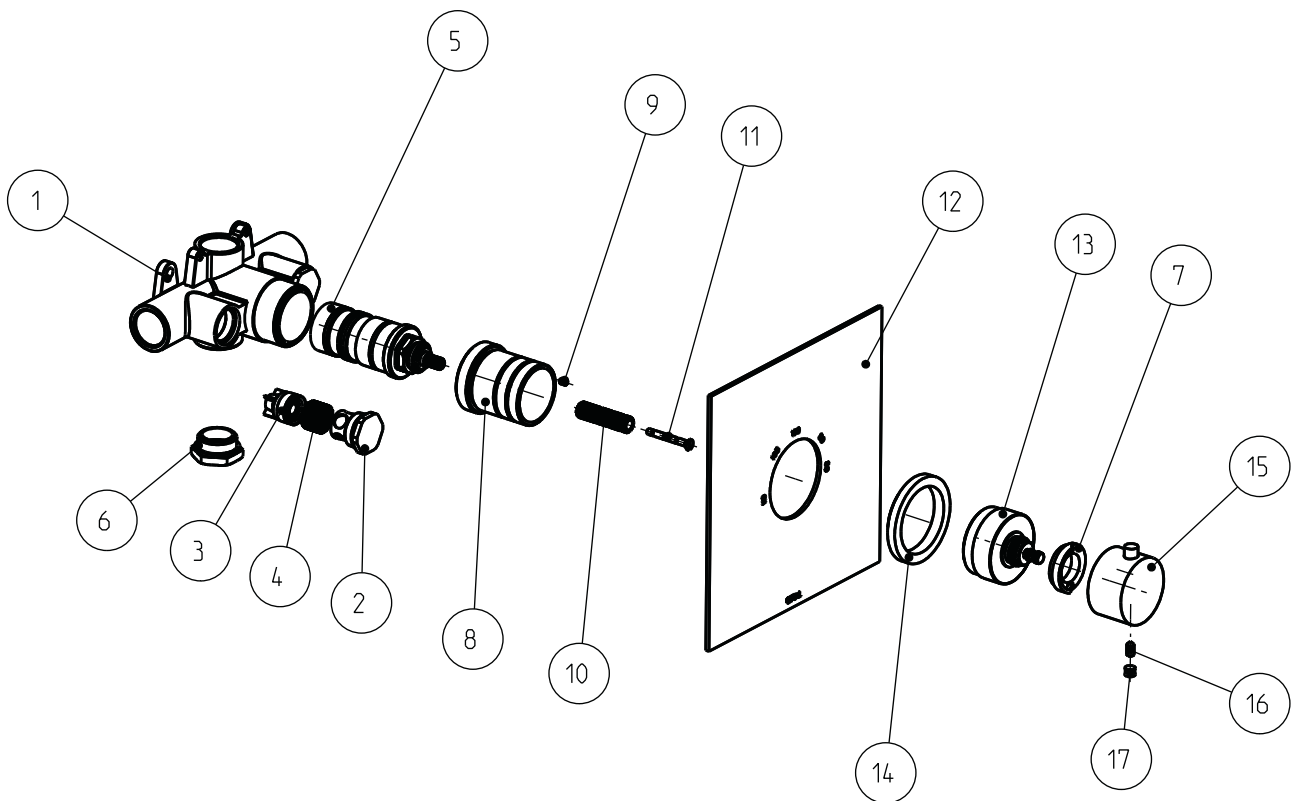

Installation

Before the trim installation, confirm the valve depth to the finished wall surface (dimension D on previous page drawing). If the valve depth fall in the range 3 1/2" - 3 7/8", install all the components as supplied. If not, the bellow components must be cutted, according to the actual valve depth (the components are grooved for that purpose).

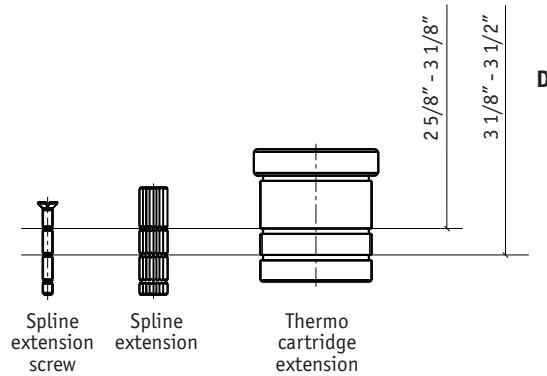

Operation

The confort zone is in the range from 90°F to 100°F, but total range is 80°F to 110°F.

Protection against scalding stops the rotation of the handle at 100°F. If water above 100°F is desired, press on the button and turn the knob counterclockwise, to prevent scalding, ensure that the handle is left in a previous position (= or <100°F).

Thermostatic valve regulation (only when needed)

1. Remove the thermostatic handle control.
2. Confirm if the temperature limit stop on the spindle present its red mark coincident with the mark 100°F on the back plate; if not amend position.
3. Open the flow control valve, let the water run, and check by a thermometer the actual temperature delivered by the valve.
It is advisable that you choose a temperature of 100°F when resetting the calibration. To accomplish that, rotate the spindle counterclockwise to increase the temperature or vice-versa. To rotate the spindle, you can use the thermostatic handle control while depressing the button, if necessary.
4. Achieving the temperature of 100°F, apply the handle aligning the button with the mark 100°F.
5. Valve setting is now calibrated according to your own operating conditions.
6. Secure the thermostatic handle control with the grub screw.

Note: It's recommended that you rotate the thermostatic control handle between the maximum and minimum limits, by pressing security button, and with the water running. This way you prevent limestone incrustation, that could block up the thermostatic cartridge.

