

650/680 SERIES INSTALLATION INSTRUCTIONS



**Gooseneck
Faucet**



**Lavatory
Faucet**



**Wall Mount
Faucet**

TABLE OF CONTENTS

| | |
|---|--|
| <p>Product Overview2</p> <p>Available Faucet Options.....2</p> <p>Common Replacement Parts.....2</p> <p>How to Order.....2</p> <p>Care and Maintenance2</p> <p>Technical Support2</p> <p>Safety Information3</p> <p>Pre-Installation Setup.....3</p> <p>Model Identification.....3</p> <p>Component Identification4</p> | <p>Installation5</p> <p style="padding-left: 20px;">Gooseneck Faucet-Single Hole & Cover Plate.....5</p> <p style="padding-left: 20px;">Gooseneck Faucet-Wall Mount.....6</p> <p style="padding-left: 20px;">Lavatory Faucet7</p> <p style="padding-left: 20px;">Solenoid and Optional Valves.....8</p> <p style="padding-left: 20px;">Electronics Assembly (AC)9</p> <p style="padding-left: 20px;">Electronics Assembly (Battery Operated).....10</p> <p style="padding-left: 20px;">Completed Installations.....11</p> <p>Faucet Operation12</p> <p>Changing Faucet Operation12</p> <p>Troubleshooting13</p> <p>Warranty16</p> |
| <p>Las instrucciones en español comienzan en la pagina18</p> <p>Les instructions en français commencent a la page36</p> | |



Trademarks

The Galileo 650/680 Series faucet spout design is licensed under U.S. patent number D446,843 S and foreign counterparts. U.S. patents pending on the Galileo 650/680 Series faucet infrared electronics design. Synapse Commander and Synapse Infrared are trademarks or registered trademarks of their respective holders.

Copyrights

© 2003 Chicago Faucets Co. All rights reserved. The information in this manual is subject to change without notice.

Notice to Installers

Please leave this manual with the facility manager after completing the faucet installation. This document contains information necessary for routine maintenance and servicing.

PRODUCT OVERVIEW

The Galileo 650/680 Series state-of-the-art motion sensing faucet systems are designed to make life safer and easier. The hands-free, touchless convenience produces a more sanitary environment and promotes water conservation. This user-friendly patented system adjusts automatically to the environment. The craftsmanship and electronics design make these faucets the best value in the market.

In addition, the Galileo 650/680 Series faucets support an optional handheld maintenance tool called Geberit Commander™. The patented Geberit Commander™ system uses wireless technology to communicate with the faucet to provide troubleshooting and maintenance information along with faucet history and status, and for making faucet adjustments.

For more information on the Geberit Commander™ system, please contact your local Chicago Faucets dealer, or www.chicagofaucets.com.

AVAILABLE FAUCET OPTIONS

4" and 8" (Centerset) Cover plate
(not available with wall mount versions)

Adjustable mechanical side-mix valve
– Catalog number 123-CP

Multi-unit hardwire transformer option for Galileo 650/652/653 Series, handles up to eight units
– Catalog number 128-NF

Single unit plug-in transformer option for Galileo 650/652/653 Series
– Catalog number 126-NF

Mixing "Y"
– Catalog number 560-045KJKRBF

Thermostatic mixing valve (requires only a single supply connection to the base fitting), handles up to 5 faucets
– Catalog number 119-NF

Stop Valve (supply-stop valves and check valves must be used when hot and cold supplies are mixed ahead of the solenoid valve) (with non-mixing valve models)
– Catalog number 441-LKC

For more information regarding faucet options, visit our website at www.chicagofaucets.com.

COMMON REPLACEMENT PARTS

| | |
|--------------------------------|--------------|
| Spout Assembly, Lavatory | 570-001KJKCP |
| 4" Cover Plate Assembly | 570-003KJKCP |
| 8" Cover Plate Assembly | 570-008KJKCP |
| Sensor Collar Assembly | 570-012KJKCP |
| Partition Assembly, DC | 570-032KJKNF |
| Partition Assembly, AC | 570-033KJKNF |
| Solenoid Wire Harness Assembly | 570-039KJKNF |
| Electronics Box Assembly, DC | 570-059KJKNF |
| Electronics Box Assembly, AC | 570-060KJKNF |
| Gasket Kit | 570-097KJKNF |
| Screw Kit | 570-098KJKNF |

| | |
|---|---------------|
| Washer Kit | 570-099KJKNF |
| 4" Cover Plate Assembly w/Side Mix Valve | 570-071KJKCP |
| 8" Cover Plate Assembly w/Side Mix Valve | 570-135KJKCP |
| Solenoid Assembly (Deck Mount) | 570-144KJKRBF |
| Solenoid Assembly (Wall Mount) | 570-145KJKRBF |
| Solenoid Rebuild Kit | 570-344KJKNF |
| Wall Collar and Elbow Assembly | 570-158KJKCP |

HOW TO ORDER

Contact your local Chicago Faucets dealer or visit our website at www.chicagofaucets.com

CARE AND MAINTENANCE

All Chicago Faucets fittings are designed and engineered to meet or exceed industry performance standards. Care should be taken while cleaning this product.

- Use of abrasive cleaners, chemicals or solvents can damage the faucet surface.
- Use mild soap with warm water for cleaning and protecting the life of the Chicago Faucets fittings. Make sure the sensor eyes are kept clean and free of obstructions.
- The solenoid assembly includes a strainer to catch particles in the water. Periodically clean the strainer to keep it from clogging.

- Close the supply lines and remove the filter nut.
- Wash or brush the strainer until clean.
- Do not overtighten the strainer when replacing.

- If water conditions are harsh, clean the solenoid and outlet (spout).

TECHNICAL SUPPORT

For additional technical assistance, visit our website at www.chicagofaucets.com, or call

1-800-TEC-TRUE (1-800-832-8783)

SAFETY INFORMATION

- Read this entire instruction sheet to ensure proper installation.
- Compliance and conformity to local codes and ordinances is the responsibility of the installer.
- Flush all the water supply lines before making connections.

- File these instructions with the owner or maintenance department.

⚠ CAUTION indicates a practice or condition that **MAY** result in damage to the equipment if the instruction or notice is ignored.

PRE-INSTALLATION SETUP

⚠ CAUTION

Make sure that water supply is completely off before beginning installation.

Galileo 650 Series (AC) Faucets

The installation site should have access to an electrical box with 120 volt AC, 60 Hz cycle for input to a transformer. When installing the 126-NF transformer, the electrical box should be within 6' of the sink. When installing the 128-NF transformer, the electrical box should be within 50' of the sink, if 18-gauge cable is used.

IMPORTANT: DO NOT attempt to operate multiple faucets using a single-fitting transformer. Always use 128-NF transformer for multiple units.

Two types of transformer are available:

- Single fitting, plug-in
 – Catalog number 126-NF
- Single fitting or multiple fittings (one to eight) hardwire
 – Catalog number 128-NF

Galileo 680 Series Battery Powered (DC) Faucets

The faucets are powered by four “AA” alkaline batteries (included).

Lavatory-style faucets are shipped with the spout, collar and cover plate assembled.

Replacing An Existing Faucet

Remove existing faucet, handles and supply lines from the sink and supply stops.

Required Tools and Supplies

Your Galileo faucet comes with all the components needed for installation, however, tools and some supplies must be furnished by you.

NOTE: Teflon tape is the recommended sealant.

⚠ CAUTION

Do not use pipe dope on faucet and supply connections. Possible solenoid contamination could occur and will void any warranty.

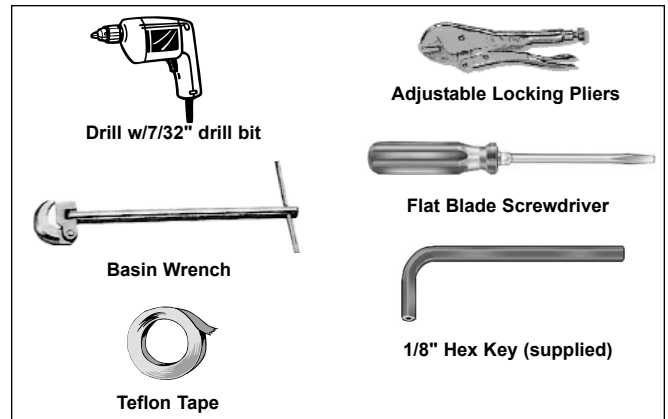

MODEL IDENTIFICATION

Gooseneck Faucet – Surface Mount

| | | |
|-----------------|-------------------------------|----|
| Model 652 | Single Hole | AC |
| Model 652-123 | w/Side Valve | AC |
| Model 652-4 | w/4" Cover Plate | AC |
| Model 652-4-123 | w/4" Cover Plate & Side Valve | AC |
| Model 652-8 | w/8" Cover Plate | AC |
| Model 652-8-123 | w/8" Cover Plate & Side Valve | AC |
| Model 682 | Single Hole | DC |
| Model 682-4 | w/4" Cover Plate | DC |
| Model 682-8 | w/8" Cover Plate | DC |
| Model 682-8-123 | w/8" Cover Plate & Side Valve | DC |

Gooseneck Faucet – Wall Mount

| | | |
|-----------|-------------|----|
| Model 653 | Single Hole | AC |
| Model 683 | Single Hole | DC |

Lavatory Faucet

| | | |
|-------------|------------------|----|
| Model 650 | Single Hole | AC |
| Model 650-4 | w/4" Cover Plate | AC |

| | | |
|-------------------|-------------------------------|----|
| Model 650-8 | w/8" Cover Plate | AC |
| Model 650-8-123 | w/8" Cover Plate & Side Valve | AC |
| Model 680 | Single Hole | DC |
| Model 680-4 | w/4" Cover Plate | DC |
| Model 680-4-123CP | w/4" Cover Plate & Side Valve | DC |
| Model 680-8 | w/8" Cover Plate | DC |
| Model 680-8-123 | w/8" Cover Plate & Side Valve | DC |

Side Mix Valve (not available with wall mount)

Model 123-CP

Mixing Y-Valve

Model 560-045KJKRBF

Thermostatic Mixing Valve

Model 119-NF

Transformers

- Model 126-NF, Plug-In
- Model 128-NF, Hardwire

COMPONENT IDENTIFICATION

Care should be taken when unpacking shipping carton to avoid damage to unit and the following components enclosed. If any parts are missing or damaged, contact your local Chicago Faucets dealer.

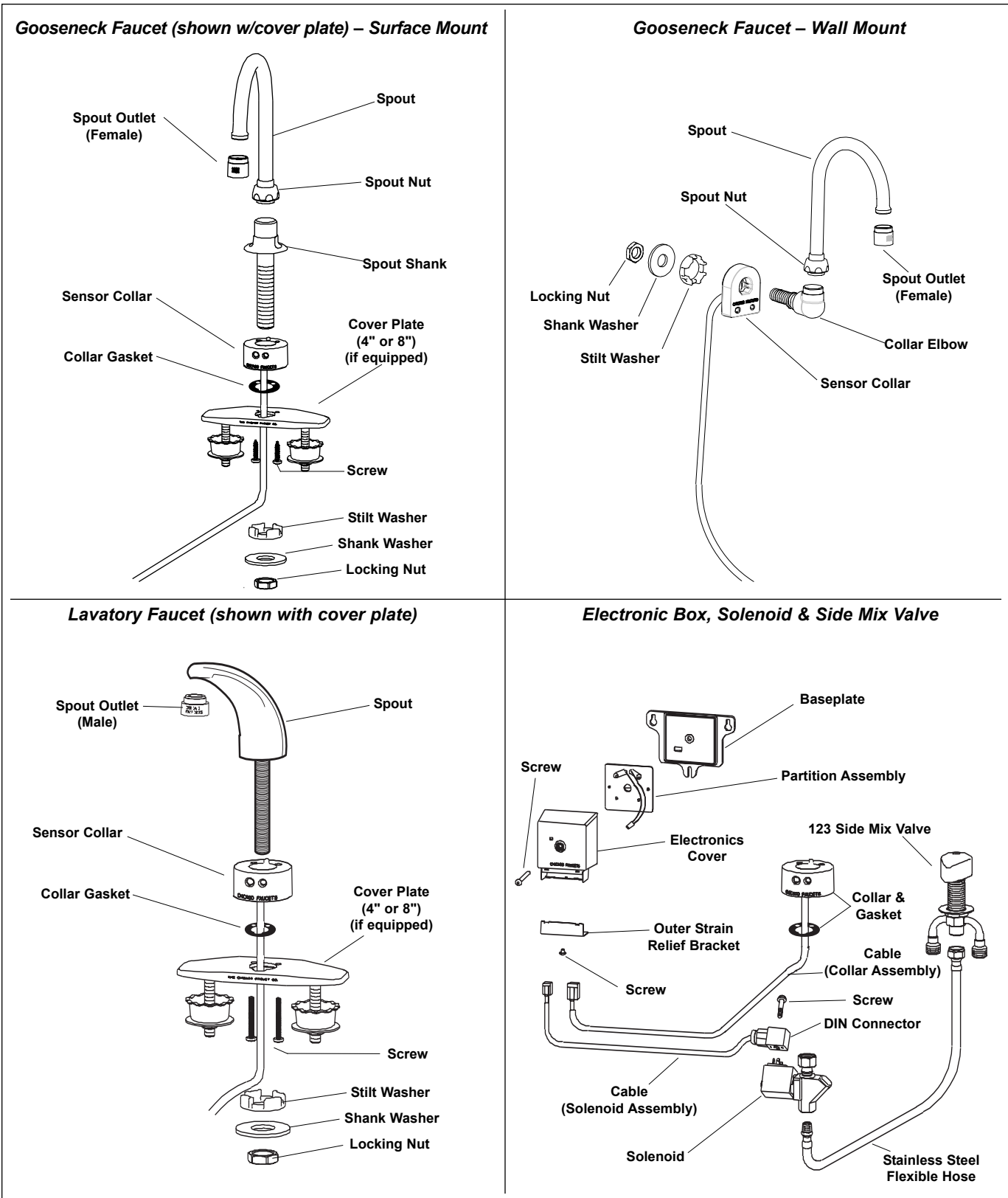

INSTALLATION – GOOSENECK FAUCET – SINGLE HOLE & COVER PLATE

1 Remove the locknut (1), washer (2), stilt washer (3) from the spout shank (4). Remove shank from cover plate (if supplied).

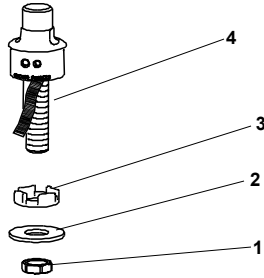

2 Install faucet assembly into deck hole. Use plumbers putty to seal faucet to deck.

Be careful not to nick or cut the sensor cable during installation.

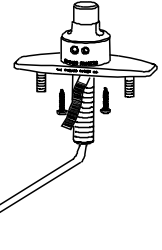

3 Install stilt washer (1) all the way up onto shank, crown side up. Position sensor cable (2) through one of the rounded slots in the stilt washer (1).

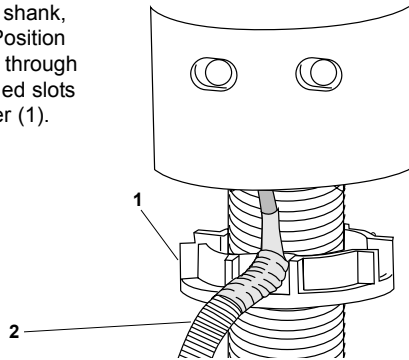

4 Install the shank washer (1) and locknut (2) onto faucet shank. Tighten locknut securely to prevent collar and spout from rotating. If necessary, support spout base from above to prevent twisting.

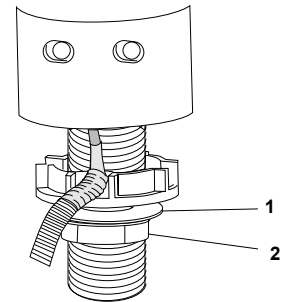

5 If faucet was installed with cover plate, secure cover plate with basin washers (1), flat washers (2) and locknuts (3).

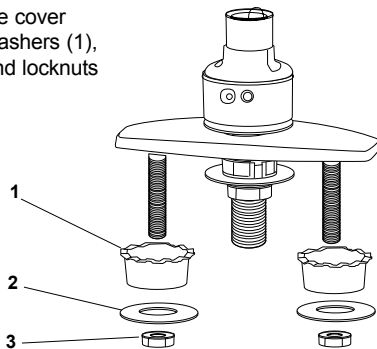

6 Install spout nut (1) onto the spout.

For swivel mount, only install two plastic split washers (2).

For rigid mount, only install 1/8" thick plastic washer (3).

Mount the spout completely into the base and securely tighten the spout nut (1).

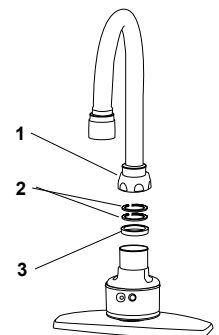

7 **CAUTION**
 Flush water lines before performing this step.

Attach the outlet assembly (1) and aerator gasket (2) to the spout. The outlet assembly is equipped from the factory with a 0.5 GPM cartridge (white screen). To configure the outlet with the 2.2 GPM cartridge (yellow screen) see step 8.

Hand icon If 0.5 GPM spout is to be used, skip step 8 and proceed to *Installation - Solenoid and Optional Valves, page 8.*

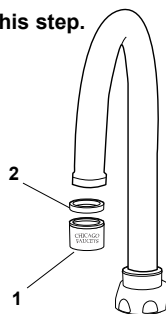

8 To convert outlet assembly to 2.2 GPM:

1. Disassemble outlet assembly using key (1).
2. Remove the 0.5 GPM cartridge (white screen) and replace it with the 2.2 GPM cartridge (2).
3. Install the rubber washer (3), adapter (4) and aerator gasket (5).

Hand icon Proceed to *Installation - Solenoid and Optional Valves, page 8.*

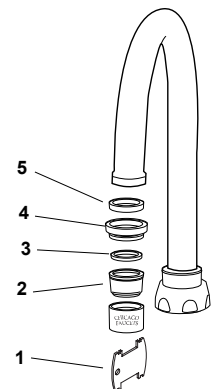

INSTALLATION – GOOSENECK FAUCET – WALL MOUNT

- 1** Remove the locknut (1), washer (2), still washer (3) from the shank (4).

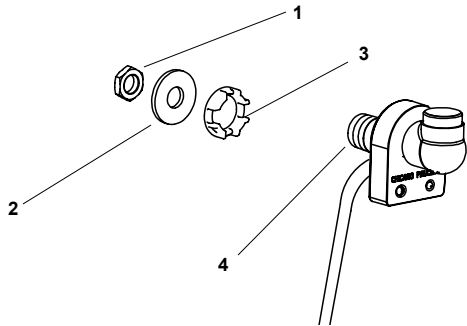

- 2** Install the sensor collar assembly into the wall hole. Install still washer (1) all the way up onto shank, crown side in. Position sensor cable (2) through one of the rounded slots in the still washer.

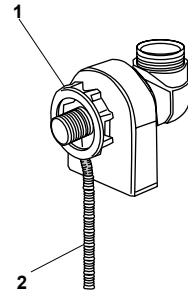

Be careful not to nick or cut the sensor cable during installation.

- 3** Install the shank washer (1) and locknut (2) onto faucet shank. Tighten locknut securely to prevent spout from rotating. Install elbow (3) using Teflon tape on threads. **NOTE:** Make sure collar is not resting on cable while tightening. Support wall collar assembly while tightening elbow.

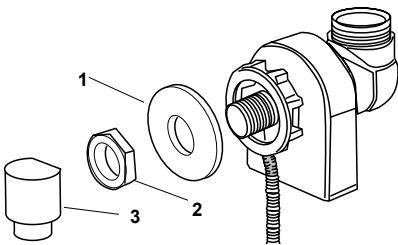

- 4** Install spout nut (1) onto the spout.

For swivel mount, only install two plastic split washers (2).

For rigid mount, only install 1/8" thick plastic washer (3).

Mount the spout completely into the base and securely tighten the spout nut (1).

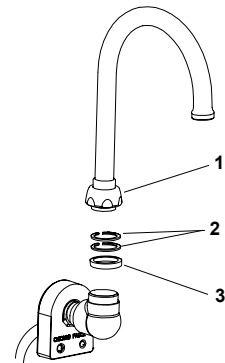

- 5** **CAUTION**
Flush water lines before performing this step.

Attach the outlet assembly (1) and aerator gasket (2) to the spout. The outlet assembly is equipped from the factory with a 0.5 GPM cartridge (white screen). To configure the outlet with the 2.2 GPM cartridge (yellow screen) see step 6.

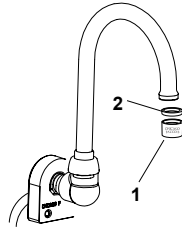

Hand icon If 0.5 GPM is to be used, proceed to *Installation - Solenoid and Optional Valves, page 8.*

- 6** To convert outlet assembly to 2.2 GPM:

1. Disassemble outlet assembly using key (1).
2. Remove the 0.5 GPM cartridge (white screen) and replace it with the 2.2 GPM cartridge (2).
3. Install the rubber washer (3), adapter (4) and aerator gasket (5).

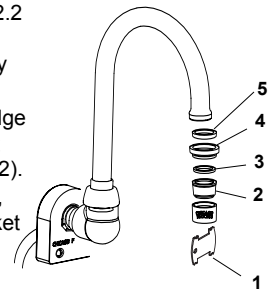

Hand icon Proceed to *Installation - Solenoid and Optional Valves, page 8.*

INSTALLATION – LAVATORY FAUCET

1 Remove the locknut (1), washer (2), stilt washer (3) from the spout shank (4).

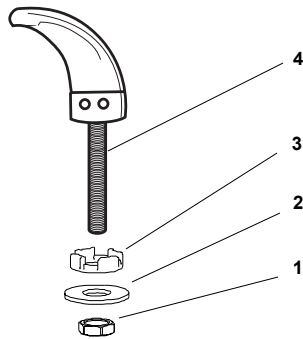

2 Install the faucet assembly into the deck hole. Use plumbers putty to seal faucet to deck.

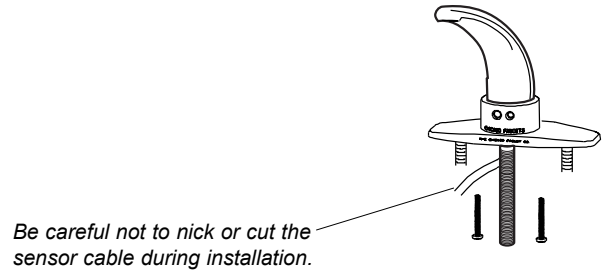

3 Install stilt washer (1) all the way up onto shank, crown side up. Position sensor cable (2) through one of the rounded slots in the stilt washer (1).

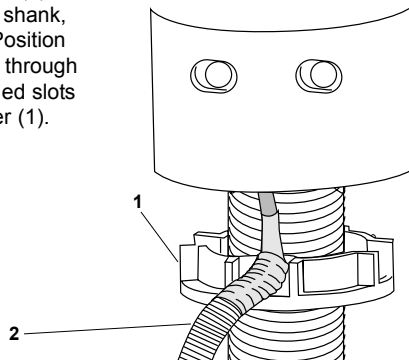

4 Install the shank washer (1) and locknut (2) onto faucet shank. Tighten locknut securely to prevent spout from rotating. If necessary, support spout base from above to prevent twisting.

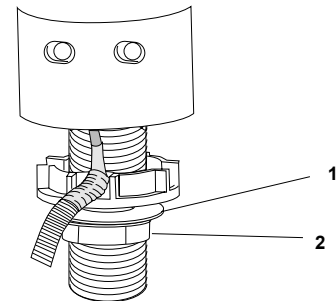

5 If faucet was installed with cover plate, secure cover plate with basin washers (1), flat washers (2) and locknuts (3).

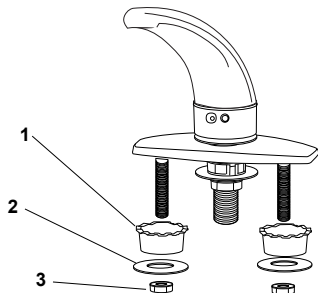

6 **CAUTION**
 Flush water lines before performing this step.

Attach the outlet assembly (1) and aerator gasket (2) to the spout. The outlet assembly is equipped from the factory with a 0.5 GPM cartridge (white screen). To configure the outlet with the 2.2 GPM cartridge (yellow screen) see step 7.

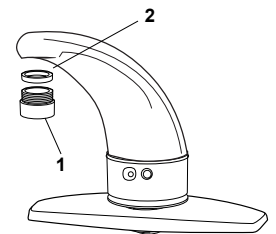

👉 If 0.5 GPM is to be used, proceed to *Installation - Solenoid and Optional Valves, page 8.*

7 To convert outlet assembly to 2.2 GPM:
 1. Disassemble outlet assembly using key (1).
 2. Remove the 0.5 GPM cartridge (white screen) and replace it with the 2.2 GPM cartridge (2).
 3. Install the rubber washer (3), adapter (4) and aerator gasket (5).

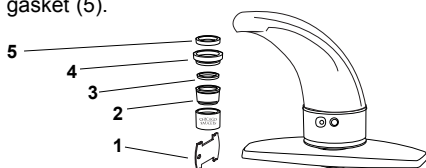

👉 Proceed to *Installation - Solenoid and Optional Valves, page 8.*

INSTALLATION – SOLENOID AND OPTIONAL VALVES

- 1** Thread the union nut (1) of the solenoid assembly to the faucet shank (2). Use **Teflon tape** on the threads to ensure a leak-free joint. Make sure the solenoid is positioned for easy access. Tighten the union nut.

CAUTION

Do not use pipe dope on threads. The solenoid could become contaminated and will void any warranty.

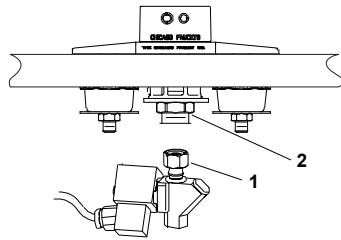

- 2** If required, install any optional equipment and connect to the solenoid. The valves listed here require only a single supply connection to the base fitting on the solenoid.

- Side mix valve (steps 3, 4, 5 & 6)
- Catalog number 123-CP
- Mixing “Y” valve (step 7)
Catalog number 560-045KJKRBF
- Thermostatic mixing valve (not shown)
- Catalog number 119-NF

- 3** If equipped with a side valve, assemble the nut (1) and flat washer (2) to the valve shank. Install the side valve assembly up into the mounting plate and secure from the top with the chrome c-clip (3) provided.

NOTE: For single-hole application substitute threaded deck flange for C-clip.

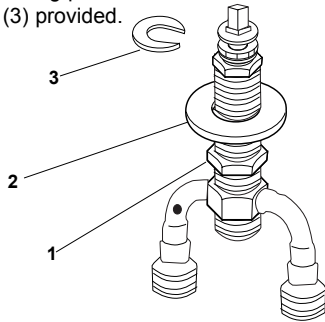

- 4** Assemble the chrome valve handle (1) to the side valve using the screw (2) and cap (3) provided.

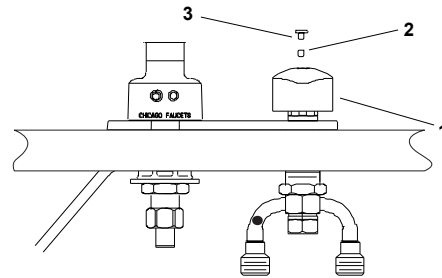

- 5** Attach the supply lines to side valve.

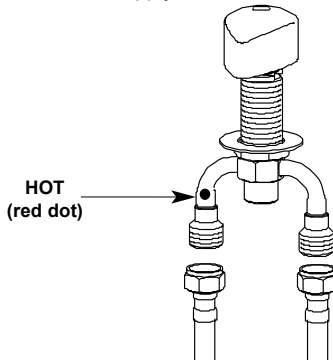

- 6** Connect the intermediate supply line (1) to the bottom outlet of the side valve and to the solenoid assembly inlet. Use Teflon tape on the threads to ensure a leak-free joint.

CAUTION

Do not use pipe dope on threads. The solenoid could become contaminated and will void any warranty.

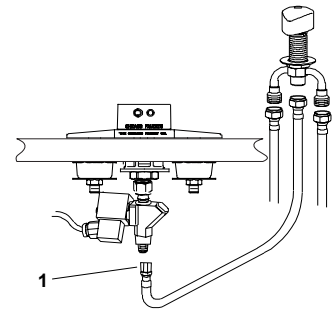

- 7** If used, assemble the “Y” valve (1) to the nipple (2) supplied, then connect the “Y” valve to the the solenoid assembly inlet. Use Teflon tape on all threads to ensure a leak-free joint.

CAUTION

Do not use pipe dope on threads. The solenoid could become contaminated and will void any warranty.

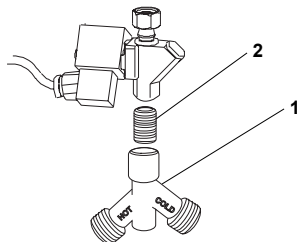

- 8** Proceed to **Installation - Electronic Box (AC or Battery Operated, depending on model)**, page 9 or 10.

INSTALLATION – ELECTRONIC BOX (AC)

1 Follow the directions on the electronic box mounting template supplied. Affix the template to the wall, either level with or above solenoid valve, and within 12" of the solenoid valve. When installing the 126-NF transformer, the electrical box should be within 6' of the sink. When installing the 128-NF transformer, the electrical box should be within 50' of the sink, if 18-gauge cable is used.

NOTE: For in-wall or multi-unit installations refer to instructions included with the transformer.

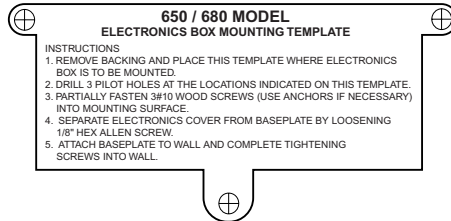

2 Install baseplate and mount the electronic box to the wall location chosen in step 1. Make sure transformer wires (1) are positioned in the baseplate channel (2) before mounting unit.

NOTE: When positioning baseplate, make sure there is enough room for drip loops in final installation. See Note in step 7.

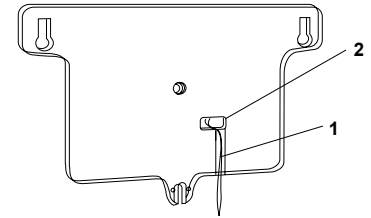

3 Remove the strain relief cover and screw (1) using hex key provided (2).

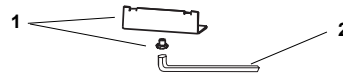

CAUTION

Do not attempt to operate multiple faucets using a 126-NF single transformer.

4 Install solenoid cable plug (1) into the smaller, telephone-style jack in the electronic box. Install faucet sensor cable plug (2) into the larger RJ-45 jack.

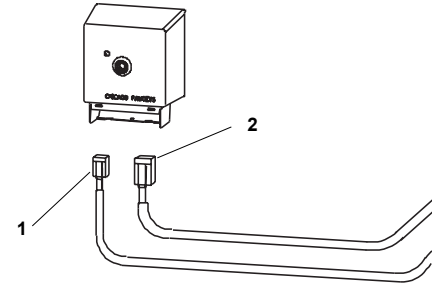

5 Attach strain relief cover (1) with screw (2) using hex key provided (3).

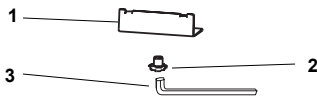
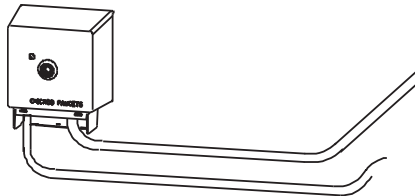

6 Feed the wires from the transformer through the baseplate. Connect the 1/4" spade terminal to the positive (+) terminal and connect the 3/16" spade terminal to the negative (-) terminal. Terminals are two different sizes and match corresponding terminal clips from transformer. Clips are not provided with the 128-NF transformer.

NOTE: The faucet will automatically calibrate when sensor cable is connected and power is supplied. See step 8.

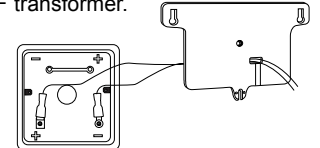

CAUTION

Faucet will automatically calibrate when sensor cable is connected and power is supplied. DO NOT place objects in front of collar sensor for first 30 seconds after power-up.

7 Re-attach the electronic box to the baseplate location using screw(1) and hex key provided (2).

NOTE: To ensure the electronic box is level with or above the solenoid valve, the cables should create a drip loop. The electronic box is designed with the wire connectors facing downward to ensure proper drip loops.

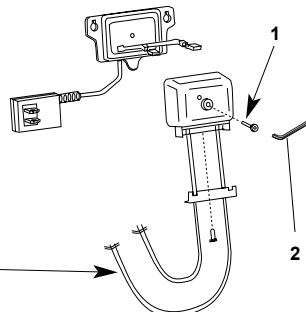

8 **CAUTION**
DO NOT turn on water supply until all electrical connections are made.

Plug the transformer into the applicable electrical receptacle. Wait at least 30 seconds, then turn on the water supply.

NOTE: When power is initially supplied, the LED on the electronic box will blink and an audible indicator chirps twice per second whenever hand presence is detected. This will continue for 8 minutes and then stop.

Proceed to FAUCET OPERATION, page 12.

INSTALLATION – ELECTRONIC BOX (BATTERY OPERATED)

- 1** Follow the directions on the electronic box mounting template supplied. Affix the template to the wall, either level with or above solenoid valve, and within 12" of the solenoid valve.

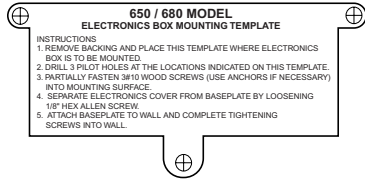

NOTE: When positioning baseplate, make sure there is enough room for drip loops in final installation. See Note in step 6.

- 2** Install baseplate and mount the electronic box to the wall location chosen in step 1.
With baseplate

NOTE: When positioning baseplate, make sure there is enough room for drip loops in final installation. See Note in step 6.

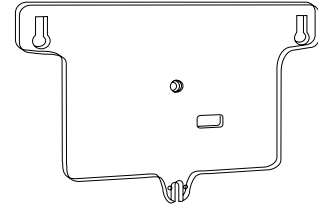

- 3** Remove the strain relief cover and screw (1) using hex key provided (2).

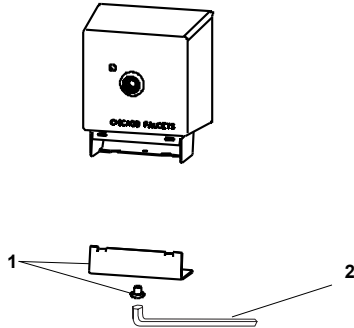

- 4** Install solenoid cable plug (1) into the smaller, telephone-style jack in the transformer. Install faucet sensor cable plug (2) into the larger RJ-45 jack.

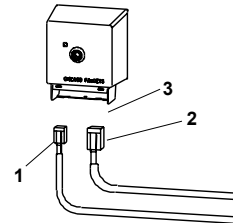

CAUTION

Faucet will automatically calibrate when sensor cable is connected. **DO NOT** place objects in front of collar sensor for first 30 seconds after power-up.

- 5** Attach strain relief cover (1) and screw (2) using hex key provided (3).

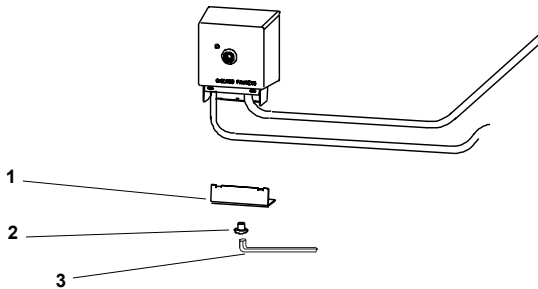

- 6** Install 4 "AA" alkaline batteries into battery holder. Observe battery polarity.

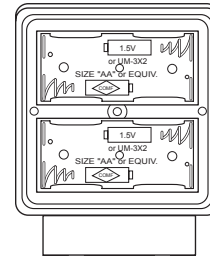

- 7** Mount the electronic box to the wall location using screw (1) and hex key provided (2).

NOTE: To ensure the electronic box is level with or above the solenoid valve, the cables should create a drip loop. The electronic box is designed with the wire connectors facing downward to ensure proper drip loops.

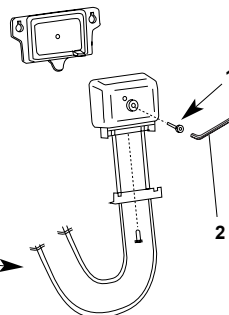

- 8** **CAUTION**
DO NOT turn on water supply until all electrical connections are made.

Turn on the water supply.

NOTE: When power is initially supplied, the LED on the electronic box will blink and an audible indicator chirps twice per second whenever hand presence is detected. This will continue for 8 minutes and then stop.

Proceed to **FAUCET OPERATION**, page 12.

COMPLETED INSTALLATIONS

Gooseneck Faucet – Surface Mount
(shown with cover plate)

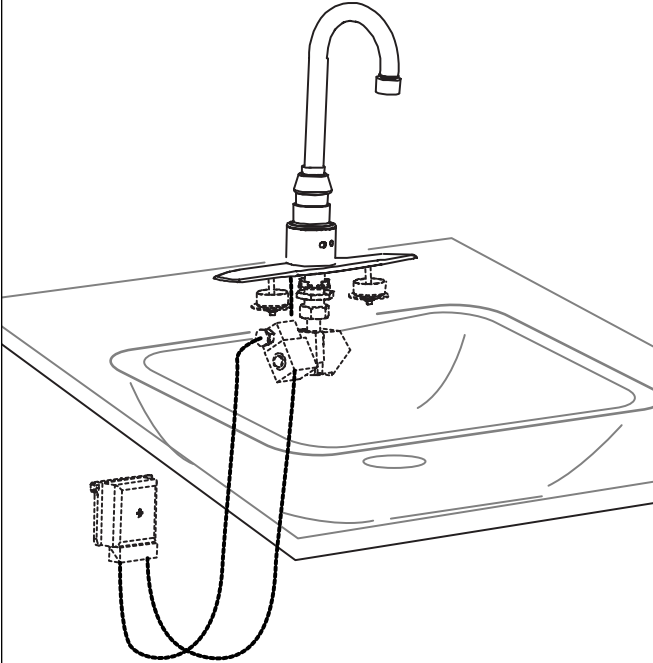

Gooseneck Faucet – Surface Mount
(shown with cover plate & side valve)

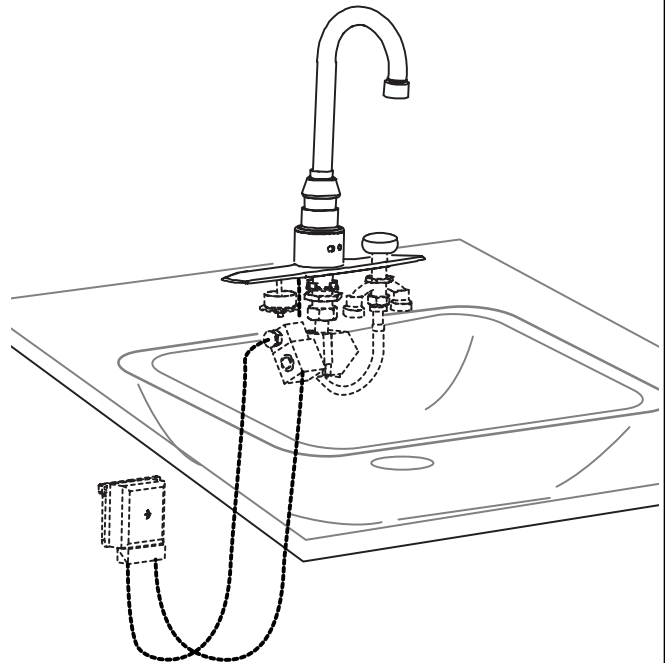

Gooseneck Faucet – Wall Mount

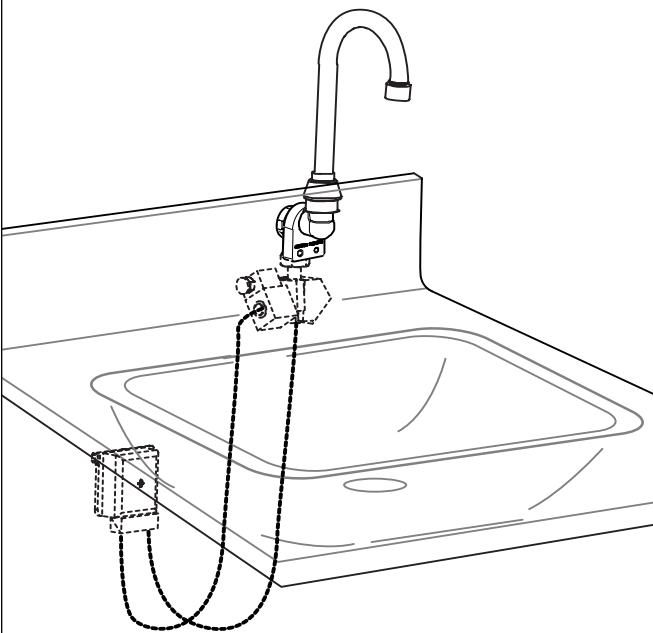

Lavatory Faucet
(shown with cover plate)

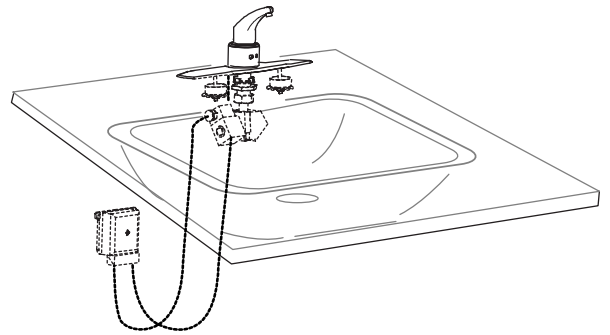

Lavatory Faucet
(shown with cover plate & side valve)

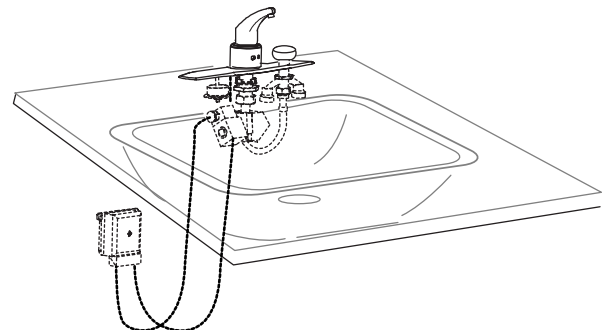

FAUCET OPERATION

Range Modes

- Normal - Gooseneck or Lavatory spout, 4-3/4" spout (factory default)
- Short - Gooseneck, 3-1/2" spout
- Far - Long Gooseneck, 5-3/8" spout
- Maximum - Long Gooseneck, 8" spout

Operating Modes

- Normal Motion Detecting Mode: water flows within 1/4 second after activating sensor (i.e., putting hands in front of collar) and continues to stay on as long as motion is detected. Maximum time is 45 seconds (factory default setting).

- Scrub Mode: water continues to flow for 60 seconds (default) after deactivating the sensor (removing hands).
- Metered Mode: water flows for 10 seconds (default) from first hand detection.
- Water Saver Mode: water flows for a maximum of 5 seconds starting from first hand detection and immediately turns off when hands are removed.

Additional Operating Features

- 12 second, no-motion turn off in normal mode
- Low-battery indication
- Battery life up to one year depending on use frequency.

CHANGING FAUCET OPERATION

In order to change any faucet option, the DIPswitch must be used (located inside the electronics cover assembly, see illustration this page).

Checking/Changing DIPswitch Settings

1. Remove the electronics cover (1) from the baseplate (2).
2. Lift the partition (3) out to expose the circuit board and DIPswitch.
3. To change a DIPswitch setting, use a small pointed object to move the appropriate DIPswitch to ON or OFF.

Faucet range and mode settings along with their corresponding DIPswitch settings are outlined in Table 1 and Table 2

Resetting Faucet Electronics

In order to reset the faucet electronics, a reset button located inside the electronics cover assembly must be pushed in (see illustration this page).

To reset faucet electronics:

1. Remove hex screw holding the electronics cover to the baseplate and remove cover.
2. Lift the partition out to expose the circuit board and reset button.
3. Make sure there are no objects in front of the collar sensor, then push the button to reset.
4. Wait 30 seconds for faucet to automatically calibrate to the environment.
5. Activate water flow by placing your hand in front of the sensor.
6. Place partition into the electronics cover.
7. Place the electronics cover onto the baseplate and secure with the hex screw.

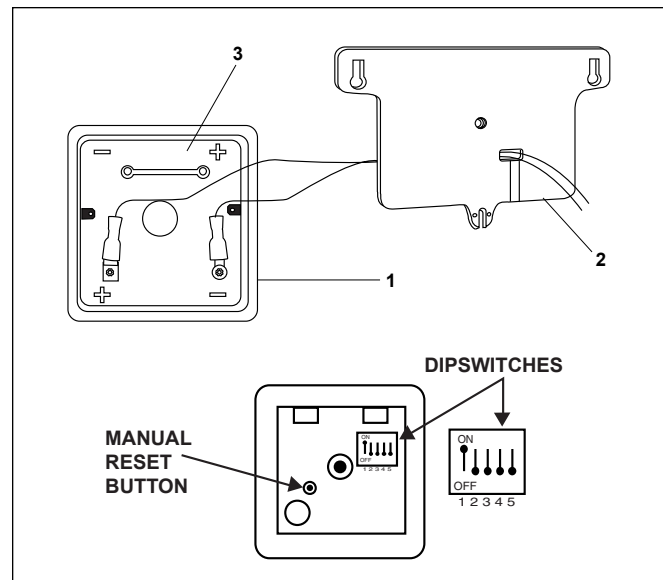

Electronics Cover Assembly & DIPswitch

| Range | Short | Normal | Far | Maximum |
|----------|-------|--------|-----|---------|
| Switch 1 | off | on | on | off |
| Switch 2 | off | off | on | on |

Table 1 - Faucet Range

| Modes | Normal Mode | Scrub Mode | Meter Mode | Water Saver Mode |
|----------|-------------|------------|------------|------------------|
| Switch 3 | off | on | off | off |
| Switch 4 | off | off | on | off |
| Switch 5 | off | off | off | on |

Table 2 - Faucet Mode

650 / 680 SERIES

Installation & Maintenance Instructions

NOTE: Resetting the faucet electronics causes loss of virtual settings and time in use, and will also start the 8 minute timer where the LED on the electronics box will blink and an audible indicator chirps twice per second whenever hand presence is detected. The optional Geberit Commander™ hand held maintenance tool can also be used to reset all faucet electronics.

The optional Geberit Commander™ handheld maintenance tool makes changing faucet operation settings easy, and provides access to additional faucet options such as delay times - all without opening the electronics cover assembly. For more information, please contact your Chicago Faucets dealer or visit www.chicagofaucets.com.

TROUBLESHOOTING

Whenever new batteries are installed, AC power is applied, or a manual reset button is pressed, the LED on the electronics cover will blink and an audible indicator chirps twice per second whenever hand presence is detected. After 8 minutes, the LED and buzzer function stops.

If an error occurs, the LED will blink and the buzzer will sound every 30 seconds to assist in diagnosing the problem. When corrective action is taken the LED and buzzer will stop.

The following chart provides details concerning the number of beeps and possible errors associated with them .

- 1 Beep:** Indicates low battery.
- 2 Beeps:** Calibration out of range (environment too reflective).
- 3 Beeps:** Room infrared level out of range; too much sunlight, heat lamp present, etc.
- 4 Beeps:** Solenoid short circuit.
- 5 Beeps:** Solenoid unplugged or loose/broken solenoid connection.

See *Troubleshooting Chart* on pages 14 & 15 for further troubleshooting information.

Troubleshooting Chart

| Problem | Check | Possible Solution |
|---------------------------------------|--|--|
| Water runs continuously. | Debris in solenoid (no beeps). | Disassemble solenoid and inspect/clean parts. |
| | Water pressure too high (no beeps). | Reduce pressure to under 80 PSI. |
| | Side mix valve installation (no beeps). | Attach side mix valve outlet to solenoid valve using flexible hose (page 8). |
| Faucet turns on by itself (ghosting). | Incorrect range setting for spout type and sink used (2 beeps). | Change range setting using DIPswitch (page 12) or Commander™ software. |
| No water flow. | Water not turned on (no beeps). | Turn on water supply. |
| | Solenoid cable not connected to electronics cover (5 beeps). | Check connection. |
| | Solenoid short circuit (4 beeps). | Replace electronics cover. |
| | Sensor cable not connected to electronics cover (no beeps). | Check connection. |
| | Inoperative sensor (no beeps). | Inspect collar wiring for signs of damage or corrosion. Replace if necessary. |
| | Inoperative electronics cover assembly (no beeps). | Replace cover assembly. |
| | Water pressure too high (no beeps). | Reduce pressure to under 80 PSI. |
| | Low battery voltage (DC only) (1 beep). | Replace batteries (DC only). |
| | 6VDC transformer not properly connected to partition assembly (no beeps). | Use correctly sized terminal clips (page 9). |
| | Wiring of multiple unit 6VDC transformer (no beeps). | Faucets must be wired in parallel from transformer (transformer to each individual unit), not connected in a series. |
| | Check wiring polarity. | If polarity was reversed, replace partition (part no. 570-033KJKNF). |
| | While communicating with faucet, the Palm device was pulled away before communications ended (no beeps). | After 60 seconds, or another Palm Communication, the faucet will return to operating mode. |
| Range too short or too long. | Interference during automatic calibration (no beeps). | Remove interference; reset electronics using reset button (page 12) or Commander™ software. Allow 30 seconds for faucet to automatically re-calibrate. |
| | Incorrect range setting for type of spout and sink used. | Change range setting using DIPswitch (page 12) or Commander™ software. |
| | Lighting environment affecting sensor (3 beeps). | Change range setting using DIPswitch (page 12) or Commander™ software. |

| Problem | Check | Possible Solution |
|-------------------------------------|--|--|
| Faucet works in reverse. | Solenoid wiring on DIN connector (no beeps). | Replace solenoid. |
| Faucet turns off too soon. | Faucet operating mode (no beeps) or faucet range setting. | Change mode or range setting using DIPswitch (page 12) or Commander™ software. |
| Faucet stays on longer than normal. | Dirty solenoid valve (no beeps). | Clean internal parts or replace solenoid valve. |
| | Clogged spout outlet. | Clean outlet. |
| | Faucet in wrong mode (no beeps). | Change mode setting using DIPswitch (page 12) or Commander™ software. |
| Faucet stopped working. | Mounting of electronics cover (no beeps). | Electronics cover must be mounted to allow for drip loops for the sensor and solenoid cables (pages 9 & 10). |
| | Sensor cable connector. | Clean connector. |
| | No clicking sound from solenoid during hand presence (no beeps). | Reset electronics using reset button (page 12) or Commander™ software. |
| | Solenoid valve strainer. | Clogged strainer. Clean if necessary. |
| | Check if faucet outlet is clogged (no beeps). | Clean faucet outlet. |
| | Battery voltage (battery operated only). | Replace batteries if below 4.2 volts. |
| | Incorrect range setting for spout type and sink used (no beeps). | Change range setting using DIPswitch (page 12) or Commander™ software. |
| No Commander™ Palm communications. | Inoperative sensor (no beeps). | Replace sensor. |

WARRANTY

PRICES - Prices quoted herein are subject to change without notice and all orders are accepted subject to prices prevailing at time of order entry.

TERMS OF PAYMENT - Terms are 2% 45 days 60 net. Cash discounts must be calculated on the total amount of the invoice, before transportation charges and any applicable taxes. A 1-1/2% per month service charge will be added to all past due invoices. Annual rate of 18%.

TAX NOTICE - Any manufacturers' or sales tax applicable thereto will be added to the prices and terms herein contained.

CREDIT APPROVAL - All orders are subject to credit approval by the CHICAGO FAUCET COMPANY'S Credit Department prior to acceptance of the order. Orders may be refused, delivery may be withheld or shipments stopped in transit on accepted orders without any liability on the Company's part, if, in its sole opinion, the buyer's ability to pay for the merchandise on the terms and conditions contained herein is in doubt. All New Accounts must submit a \$500.00 net minimum order with credit and bank references.

SHIPPING AND HANDLING - All sales are F.O.B., shipping point. The Company will allow full freight at the prevailing CWT rate on shipments of Company's products with a net invoice value of \$1,500.00 or 24 pieces, * when shipments are within the continental United States and have as destination the buyer's usual business address or designated job location. Freight allowed on shipments to Alaska shall be calculated F.A.S., Seattle, Washington. The use of the term "F.A.S., Seattle, Washington" in this paragraph shall not be deemed to impose any risk or obligation concerning the goods or the shipment thereof upon the Company after the delivery of the goods to the initial carrier. Under no circumstances will a direct C.O.D. shipment be made to the wholesaler's customer.

* Original P.O. must meet FFA terms. Subsequent additions will not be considered towards freight allowance.

Routing of shipments shall be determined at the sole discretion of the Company.

DELIVERY - Delivery to the initial carrier shall constitute delivery to the buyer. CHICAGO FAUCET COMPANY'S responsibility, insofar as transportation risks are concerned, ceases upon delivery in good order to such carrier, and all goods are shipped at the buyer's risk. The buyer is requested to check each incoming shipment carefully before acknowledging receipt from the carrier. If goods are visibly damaged the buyer should insist that written confirmation of the damage be noted on the freight bill by the carrier. If concealed damage is noted after unpacking, the buyer should immediately notify the carrier involved and obtain verification of the damage from the carrier.

Claims for shortages in orders will not be considered unless presented to the Company within 30 days after receipt of goods by the buyer.

DAMAGE - All claims for damage in transit, shortage, or nondelivery must be filed against the carrier by the buyer.

CHICAGO FAUCET COMPANY will not be responsible for delay in shipment of goods, or for any damages suffered by reasons thereof, when such delay is occasioned by accident, fire, flood, embargo, strike, war, labor stoppages, inadequate transportation, shortage of materials, delay or default on the part of vendors, government regulations or any other cause beyond its control.

CHICAGO FAUCETS BRAND PRODUCTS ARE SUBJECT TO THE FOLLOWING WARRANTIES:

LIMITED WARRANTY - The CHICAGO FAUCET COMPANY ("Chicago Faucets") extends to the original consumer the following warranties for Genuine Chicago Faucets manufactured products and components, or other components under the Chicago Faucets Warranties, (collectively, the "Products") used in commercial or residential applications.

LIFETIME FAUCET WARRANTY - The "Faucet", defined as any metal cast, forged, stamped or formed portion of the Product, not including electronic or moving parts or water restricting components, or other components covered under other Chicago Faucet warranties, is warranted against manufacturing defects for the life of the Product.

FIVE YEAR CARTRIDGE WARRANTY - COMMERCIAL - The "Cartridge", defined as the metal portion of any Product typically referred to by the product numbers containing 1-099, 1-100, 1-310, 377X, 217X and 274X, excluding any rubber or plastic components, is warranted against manufacturing defects for a period of five (5) years from the date of Product purchase. All Cartridges included in Chicago Faucet's Single Control or Shower Products are also warranted against manufacturing defects for a period of five (5) years from the date of Product purchase.

LIFETIME CARTRIDGE WARRANTY - RESIDENTIAL - For products used in Residential applications, the "Cartridge", as described above, is warranted for the lifetime of the faucet.

ONE-YEAR FINISH WARRANTY - COMMERCIAL - For Products used in commercial applications, the finish of the Product is warranted against manufacturing defects for a period of one-year from the date of Product purchase. PVD finishes installed in public or commercial areas carry a one-year warranty from date of installation.

ONE-YEAR FINISH WARRANTY - RESIDENTIAL - PVD finishes installed in public or commercial areas carry a one-year warranty from date of installation.

650 / 680 SERIES

Installation & Maintenance Instructions



FIVE-YEAR FINISH WARRANTY - RESIDENTIAL - For Products used in residential applications, the finish of the Product is warranted against manufacturing defects for a period of five (5) years from the date of Product purchase. ForeverShine™ finishes installed in residential-use applications are warranted not to corrode, tarnish or discolor for the life of the product.

ELECTRONIC FAUCETS MECHANICALS WARRANTY - Are warranted for 5 years from the date of installation.

ELECTRONIC FAUCETS FINISHES WARRANTY - Are warranted for one-year from the date of installation.

ELECTRONIC FAUCETS ELECTRONICS AND SOLENOID WARRANTY - Are warranted for one-year from the date of installation.

OTHER WARRANTIES - All other Products not covered above are warranted against manufacturing defects for a period of one (1) year from the date of Product purchase.

GEBERIT BRAND PRODUCTS ARE SUBJECT TO THE FOLLOWING WARRANTIES:

KITCHEN ACCESSORIES shall be free from defective material and workmanship for a period of 1-year from date of installation.

BATH WASTE and OVERFLOW products carry a limited lifetime warranty on the material and mechanism

Tessera™ concealed tank & carrier units carry a 10-year limited warranty on the flushing mechanisms and limited lifetime warranty on the tank and carrier.

PLATED FINISHES carry a one-year limited warranty from date of installation with the exception of those finishes designated as ForeverShine™.

ForeverShine™ finishes installed in residential-use applications are warranted not to corrode, tarnish or discolor for the life of the product.

ForeverShine™ finishes installed in commercial use applications are warranted for a period of one-year from date of installation.

ELECTRONIC FAUCETS, FLUSHOMETERS AND METERING MECHANICALS WARRANTY - Are warranted for 5 years from the date of installation.

ELECTRONIC FAUCETS FINISHES WARRANTY - Are warranted for one-year from the date of installation.

ELECTRONIC FAUCETS ELECTRONICS AND SOLENOID WARRANTY - Are warranted for 3 years from the date of installation.

PRESSURE ASSIST TOILET SYSTEMS - Are warranted for 5 years from date of installation (pressure vessel), limited lifetime for the carrier plus a one-year warranty on toilet bowl and flush actuator plate.

Chicago Faucets will either replace or repair the defective equipment or refund the purchase price, at its option, if an inspection by Chicago Faucets or its authorized representative discloses any manufacturing defects in material or workmanship during this period. These provisions do not include the battery shipped with the Electronic Products. Chicago Faucets will not be liable for any labor or other expenses not specifically stated above and disclaim any responsibility for incidental or consequential damages.

Warranties implied by law, including that of merchantability are expressly limited to the period of this warranty. This limitation and exclusion does not apply in those states that do not allow limitations on the duration of implied warranties. Or the exclusion may not apply to you. This warranty gives you specific legal rights and you may have other rights, which vary, from state to state.

RETURNED GOODS - Merchandise may not be returned to the Company for credit unless the buyer obtains prior written approval from the Company. Such approval will be granted only when material to be returned is a Standard or MTO product and is listed in the current price sheets. Credit will be issued on all material returned by permission, at the prevailing price at time of purchase, less a handling charge of up to 35%. No credit whatever will be allowed on products designated as Custom (Custom products are products not designated as Standard or MTO) which have been shipped according to customers' specification. Material, which is marred or damaged, will not be accepted. All transportation costs for returned goods must be paid by the buyer.

ORDER MODIFICATION/CANCELLATION - Orders for Standard and MTO products can be modified or cancelled up to the time the order is being processed for shipment. A Chicago Faucets customer service representative must confirm the status of order to be cancelled or changed in order to avoid any restocking fees or charges. Changes to the order can potentially extend the acknowledged availability date. Once entered, Custom products are non-cancelable, and will be shipped and billed to the customer.

The Company reserves the right to make reasonable changes of any kind in its products and their packaging without notice.

MINIMUM CHARGE - No invoice will be made for less than \$100.00 (One Hundred Dollars Net) on faucets, valves and fittings or repair parts.

NOTE: Possession of this price sheet by any person is not to be construed as an offer to sell him or anyone else, the goods listed herein at prices stated.